



## OPERATING INSTRUCTIONS

# FlowJam A

MATERIAL FLOW DETECTION FOR HOSE LINES



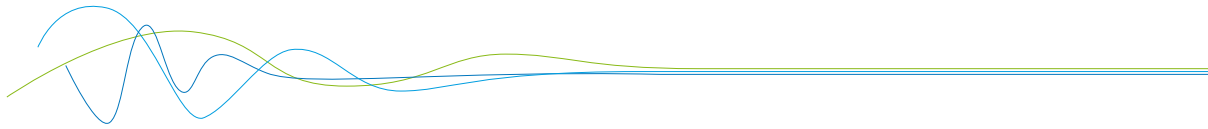

## CONTENTS

Page

1. Function .....	3
2. Safety .....	4
3. Mounting and installation .....	5
3.1 Basic remarks .....	5
3.2 Installation of the sensor in general .....	5
4. Electrical connection .....	6
5. Commissioning .....	7
6. Troubleshooting .....	8
7. Notice .....	8
8. Declaration of conformity .....	8
9. Technical data .....	9

## 1. Function

The microwave-based detector FlowJam A indicates the flow of bulk materials which moves through the detection range at a minimal required speed of 0.1 m/s.

The detection is executed by evaluating the Doppler's effect, thus independent of the flow direction.

The material flow is indicated by relays.

The sensor distinguishes between two conditions:

- material flow
- material jam or standstill.

The Flowjam A is suitable for hose diameters between 2 and 10 mm (hoses with with metal inlay or liners cannot be used)

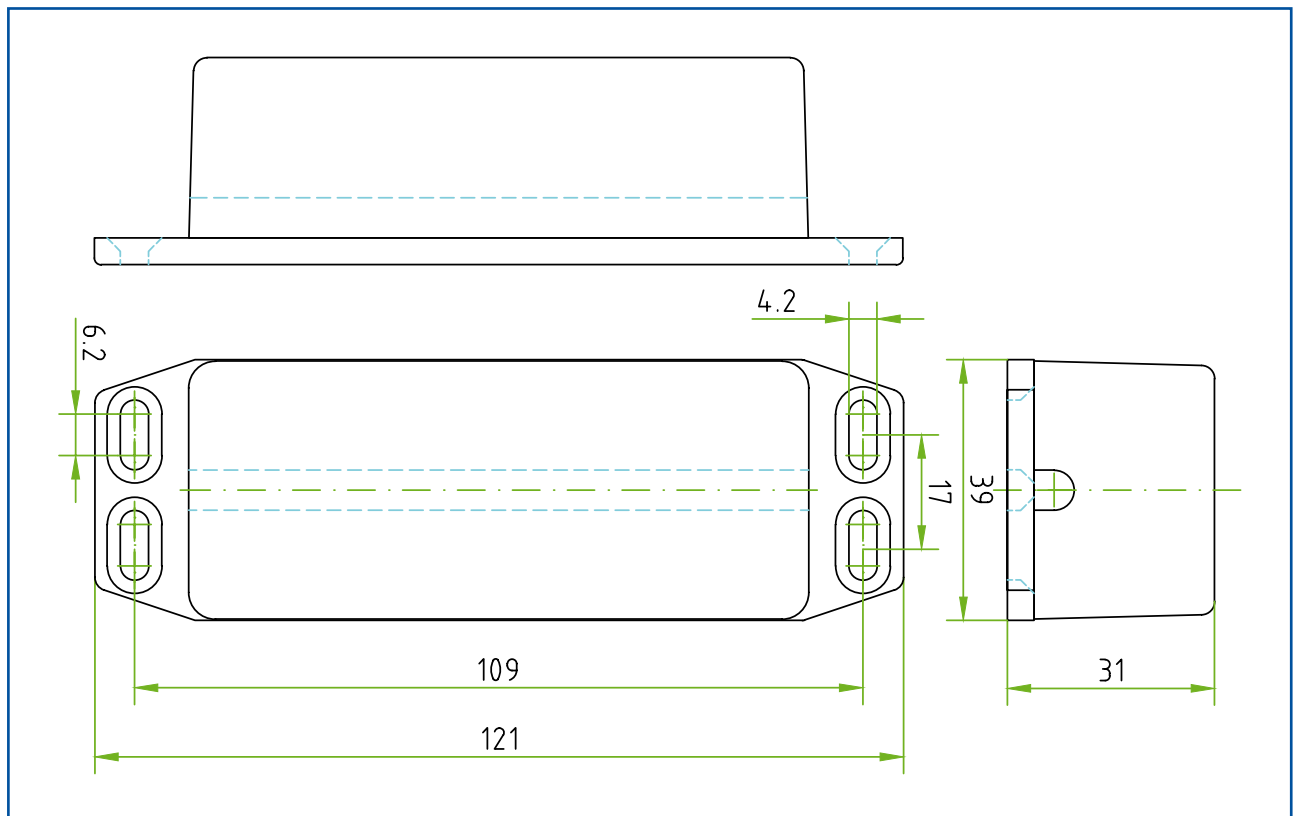
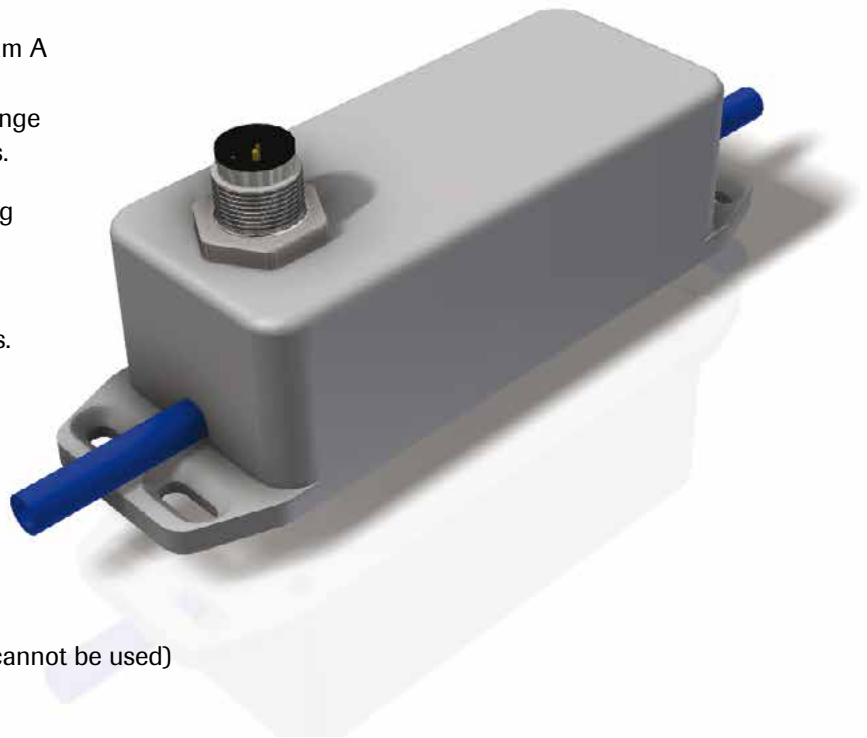

Fig. 1: Dimensional drawing

## **2. Safety**

The sensor FlowJam A was designed, built and tested to be safe and was shipped in safe condition. Nevertheless persons or objects may be endangered by components of the system if these are operated in an inexpert manner. Therefore the operational instructions must be read completely and the safety notes must be followed.

In case of inexpert or irregular use, the manufacturer will refuse any liability or guarantee.

### **2.1 Regular use**

- Only original spare parts and accessories of ENVEA Process must be used.

### **2.2 Identification of dangers**

- Possible dangers when using the sensor are marked in the operating instructions.

### **2.3 Operational safety**

- The sensor must be installed by trained and authorised personnel only.
- Switch off the power supply for all maintenance, cleaning or inspection works on the tubes or on components of the FlowJam A.
- Before hot work the sensor must be removed from the installation place.
- The components and electrical connections must be checked for damages regularly. If a damage is found, it is to be repaired before further operation of the instruments.

### **2.4 Technical progress**

- The manufacturer reserves the right to adapt technical data to the technical progress without particular advance notice. If you have any questions, ENVEA Process will be pleased to inform you on possible changes and extensions of the operating instructions.

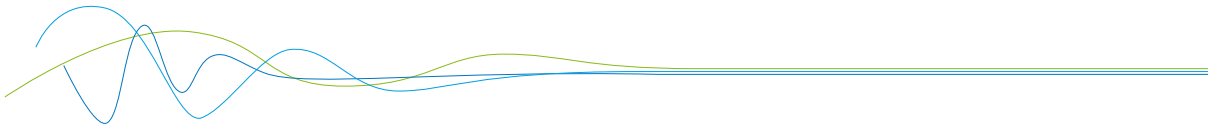

### 3. Mounting and installation

#### 3.1 Basic remarks

Be careful to mount the sensor in an absolutely vibration-free area and that no parts within the detection range are moving, because this might be detected as a material flow.

#### 3.2 Installation of the sensor in general

The installation of the sensor depends on the conditions of the site.

When mounting the sensor, make sure that the sensor is fixed on a grounded plate before commissioning to avoid damages due to electrostatic charge.

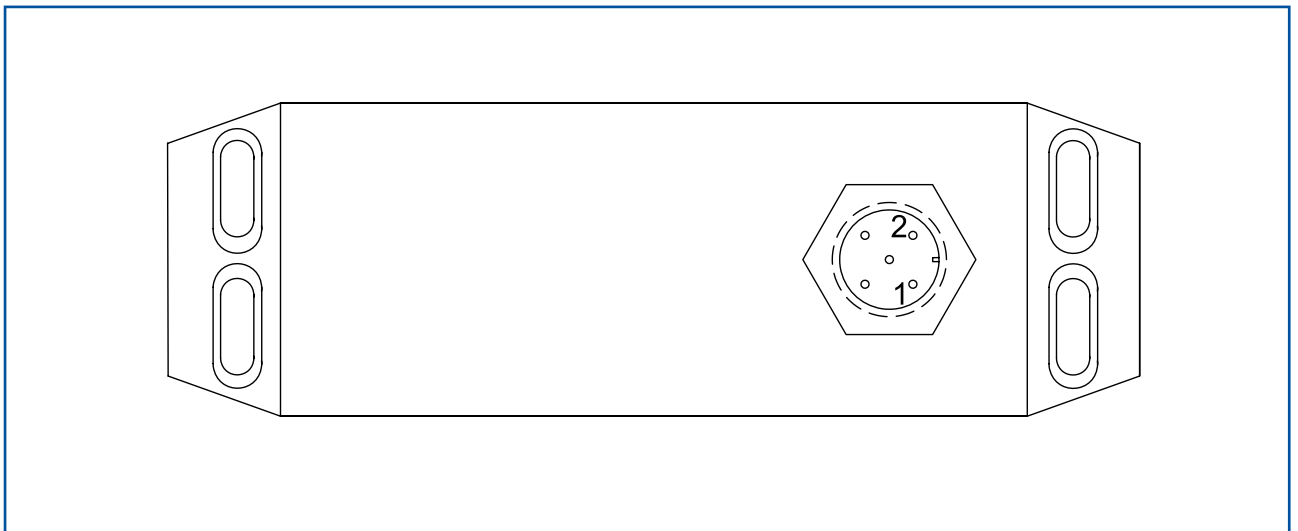
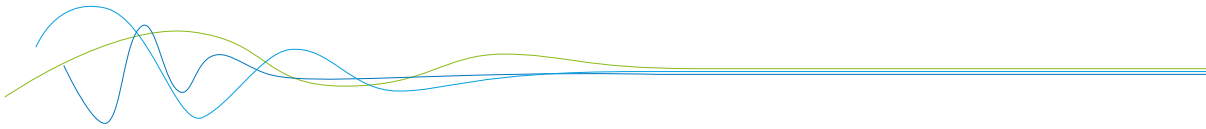

Fig. 2: Pin assignment





#### 4. Electrical connection

A maximum length of 300 m cable between sensor and Evaluation unit should not be exceeded.

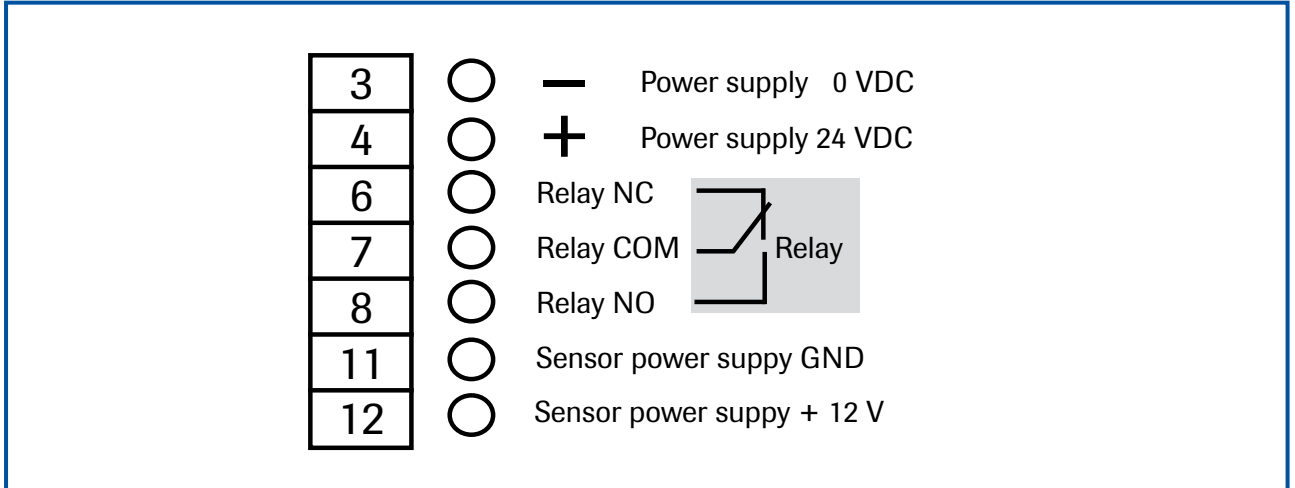

Fig. 3: Wiring diagram for DIN Rail electronic

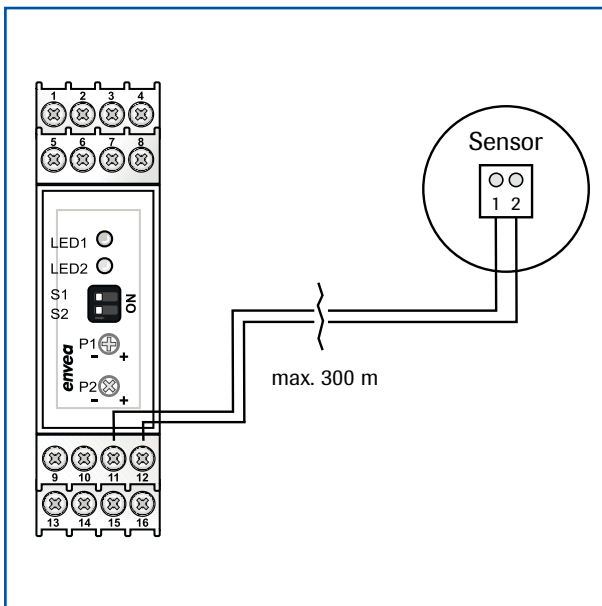

Fig. 4: Wiring of sensor and DIN Rail electronic



Fig. 5: FlowJam A and DIN Rail electronic

## 5. Commissioning

All operational controls required for the alignment are shown in fig. 11.

Control elements:

- LED 1: Signal strength
- LED 2: Material flow
- S1: Switching between working current / closed current
- S2: Coarse adjustment of sensitivity
- P1: Threshold level
- P2: Delay time

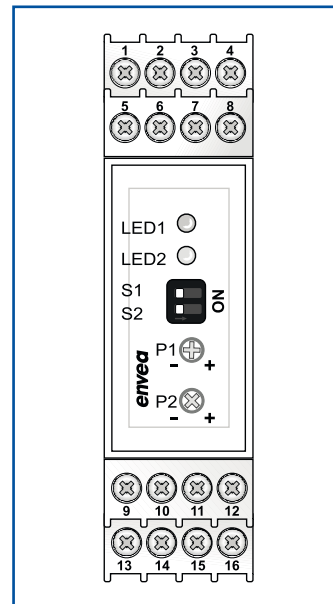

Fig. 6: Position of control elements

### Switch S1

The position of switch S1 determines, whether the relay is attracted up or released at material flow.

Position "2" (off) causes alarm in case of material flow:

- material flow - relay is attracted  
- contacts 7 + 8 closed
- no material flow - relay is released  
- contacts 6 + 7 closed

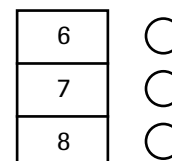

Position "1" (on) causes alarm when there is no material flow:

- material flow - relay is released  
- contacts 6 + 7 closed
- no material flow - relay is attracted  
- contacts 7 + 8 closed

### LED 1

The LED 1 (red) lightning shows the signal strength by its luminosity; that is, no lightning if no reception signal (no material flow, no vibrations, etc.), weak lightning if low and strong lightning if intense reception signal.

### LED 2

The LED 2 (green) lights always up, if material flow is detected; this display is independent of the position of the switch S1.

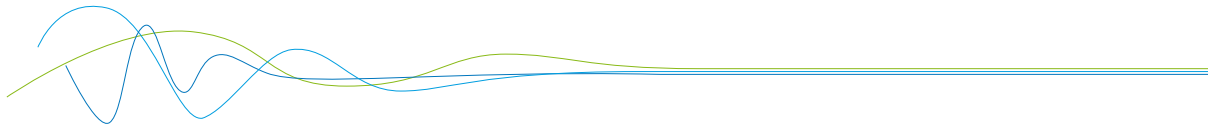

### Adjustment of sensitivity

Hereto use switch S2, potentiometer P1 and potentiometer P2.

The control elements are in the following positions at the delivery (this basis is crucial for the commissioning):

- P1 (fine adjustment of sensitivity): at the left lay, thus insensitive
- S2 (coarse adjustment of sensitivity): switch at (on), thus relatively insensitive
- P2 (delay time): at the left lay, thus minimal delay of 250 ms

Now start your machine in order to guarantee material flow. In consequence the LED 1 must light-up. If the LED 1 doesn't light-up, then the switch S2 has to be set on (off).

Now choose the position of the switch S1 accordingly, if the relay has to be turned (on) or (off) at material flow.

Enhance the sensitivity so long until the LED 2 glows and the relay switches (off) or (on).

If you interrupt the material flow, both LED lightning must go out, whereas the LED 2 goes out at the latest if the delay time ends.

Finally, you can adjust the delay time according to your requirements with potentiometer P2 in the range of 250 ms ... 15 s.

## 6. Troubleshooting

If LED 1 does not light up even at the largest possible amplification, the following points must be checked:

- properties of the material flow (see e. g. fig. 7)
- positioning of the installation
- distance between the sensor and the material flow

If LED 1 lights up without an existing material flow and with minimal amplification adjusted on S2 and P1, it is very likely that the sensor detects the motion of something else or vibrations.

**Attention:** Does the LED 1 lights up continuously, then either there is no connection between sensor and DIN Rail electronic, or the sensor is broken!

## 7. Notice

- Avoidance of reflection by vibration or moving line parts
- Setting of the amplification by potentiometer P1 until just of the switching threshold (LED 2 glows)

## 8. Declaration of conformity

Conforms to the following product specifications:

Number: 89/336/EEC

Text: Electromagnetic Compatibility

The product herewith complies to requirements of the EMC directive 89/336/EEC:

Reference no.	Date	Reference no.	Date
DIN EN 55011	2007	DIN EN 61000-4-3	1997
DIN EN 61000-1		DIN EN 61000-6-1	2002
DIN EN 61000-3-2	2001	DIN EN 61000-6-2	2000
DIN EN 61000-3-3	2001	DIN EN 61000-6-3	2002



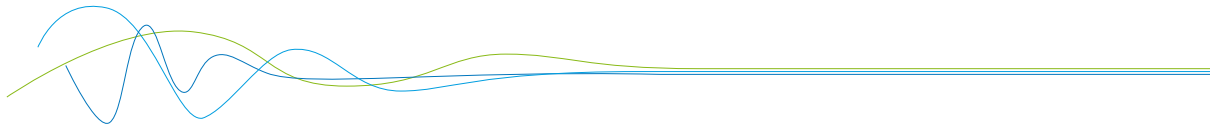

## 9. Technical data

<b>Sensor</b>	
Power supply	12 V DC powered by Evaluation unit
Power consumption	approx. 1.5 W
Housing	Aluminium
Protection system	IP65
Process temperature	- 20 ... + 60 °C
Ambient temperature	- 20 ... + 60 °C
Required material speed for detection	min. 0.1 m/s
Measuring frequency	K-Band 24.125 GHz / ± 100 MHz
Transmitting power	max. 5 mW
Dimensions	Housing: L 122 mm / W 39 mm / H 44 mm
Weight	approx. 190 g

<b>Evaluation unit</b>											
Power supply	24 V DC ± 10 %										
Power consumption	20 W / 24 VA										
Protection System	IP40 according to EN 60 529										
Ambient temperature	-10 ... +45 °C										
Fall-delay time	250 ms ... 15 s (continuously adjustable)										
Dimensions	23 x 90 x 118 (W x H x D)										
Weight	Approx. 172 g										
DIN rail mounting	DIN 60715 TH35										
Terminal cross-section	0.2 – 2.5 mm <sup>2</sup> [AWG 24-14]										
Relay contact	<table border="0"> <tr> <td>Max. rated load:</td> <td>250 V AC</td> </tr> <tr> <td>Max. peak current:</td> <td>6 A</td> </tr> <tr> <td>Max. rated load 230 V AC:</td> <td>250 VA</td> </tr> <tr> <td>Max. breaking capacity DC1: 3/110/220 V:</td> <td>3/0.35/0.2 A</td> </tr> <tr> <td>Min. switching load:</td> <td>500 mW (10 V/5 mA)</td> </tr> </table>	Max. rated load:	250 V AC	Max. peak current:	6 A	Max. rated load 230 V AC:	250 VA	Max. breaking capacity DC1: 3/110/220 V:	3/0.35/0.2 A	Min. switching load:	500 mW (10 V/5 mA)
Max. rated load:	250 V AC										
Max. peak current:	6 A										
Max. rated load 230 V AC:	250 VA										
Max. breaking capacity DC1: 3/110/220 V:	3/0.35/0.2 A										
Min. switching load:	500 mW (10 V/5 mA)										
Data backup	Flash Memory										

